

MILLAU BRIDGE, 2004
Norman Foster

PROFLEX ACC

STAINLESS STEEL AISI 304/1.4301-V2A
+ VINYL RESIN / RUBBER INSERT

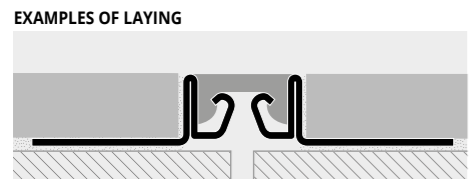
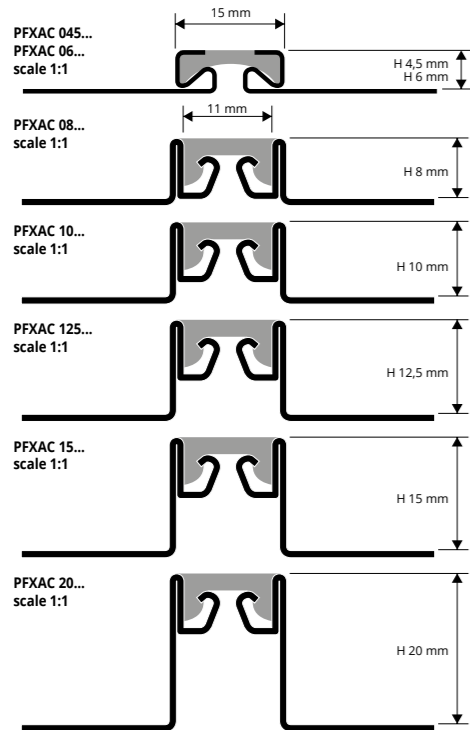

PROFLEX ACC is a new, stainless steel expansion joint with interchangeable (H. 4,5 e 6 mm excluded) vinyl resin/rubber insert, available in black, grey, beige or ivory. PROFLEX ACC provides elastic expansion joints for various kinds of flooring, such as ceramic, marble, granite, Kerilite/Laminam or any other flooring material laid with glue/adhesive and having a thickness of 4,5 to 20 mm. The joint is specially designed to protect the edges of the tiles, and its exceptional strength makes it capable of supporting frequent traffic, both pedestrian and vehicular (forklifts, pallet trucks, automobiles). The joint must be installed at the same level of the floor or 0.5-1 mm lower (never above). Lay the joints according with the standards in force. HIGH RESISTANCE TO LOADS AND TO FREQUENT TRAFFIC OF PALLET TRUCKS AND FORKLIFTS.

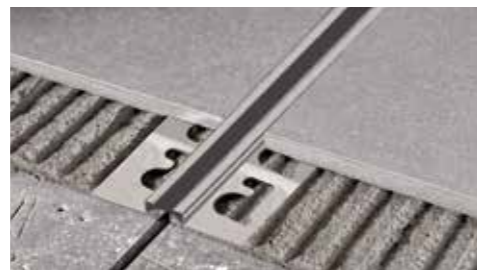

POLISHED STAINLESS STEEL AISI 304/1.4301-V2A
+ VINYL RESIN / RUBBER INSERT
bar length 2,5 lm - pack. 20 Pcs - 50 lm

Article	H mm	€/lm	€/Pc
PFXAC 045...	4,5	20,41	51,03
PFXAC 06...	6	21,26	53,15
PFXAC 08...	8	25,60	64,00
PFXAC 10...	10	25,91	64,78
PFXAC 125...	12,5	26,66	66,65
PFXAC 15...	15	27,82	69,55
PFXAC 20...	20	29,83	74,58

SUITABLE FOR USE IN CONTACT WITH FOODSTUFFS

LAYING INSTRUCTIONS

1. Choose the PROFLEX ACC with the same height as the thickness of the floor (tile) also choosing the colour of the insert. 2. Using a notched spreader apply the adhesive in the point where the joint will be laid. 3. Lay the PROFLEX ACC with the punched flanges in the adhesive (we recommend the expansion joint being laid in line with the joint in the screed/floor rough). 4. Lay the tiles, aligning them with and adjoining the upper edge of the profile (the joint must always be 0.5-1mm lower than the tile, never above). Always place the uncut side of the tile against the profile. 5. Use sealant to fill any spaces between the tile and the PROFLEX ACC joint.



VINYL RESIN/RUBBER INSERT

Article	H mm	€/lm	€/Pc
ISPFXAC 820...	8-10-12,5-15-20	3,34	8,35

VINYL RESIN/RUBBER INSERT

Article	H mm	€/lm	€/Pc
ISPFXAC 045...	4,5	3,07	7,68
ISPFXAC 06...	6	3,07	7,68

Insert available in the colours: G - N (Beige and Ivory available on demand with a minimum quantity order of 200 pcs). The code of the selected finish must be added to the article code. E.g.: PFXAC 045... (chosen insert colour grey) PFXAC 045G.

COLOURS



ON DEMAND MINIMUM QUANTITY 200 PCS for colour and height

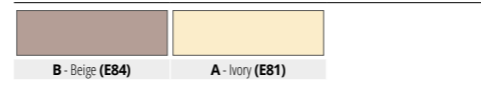

(price and delivery time to be agreed)

PROFLEX ACC PR

STAINLESS STEEL AISI 304/1.4301-V2A
+ VINYL RESIN / RUBBER INSERT

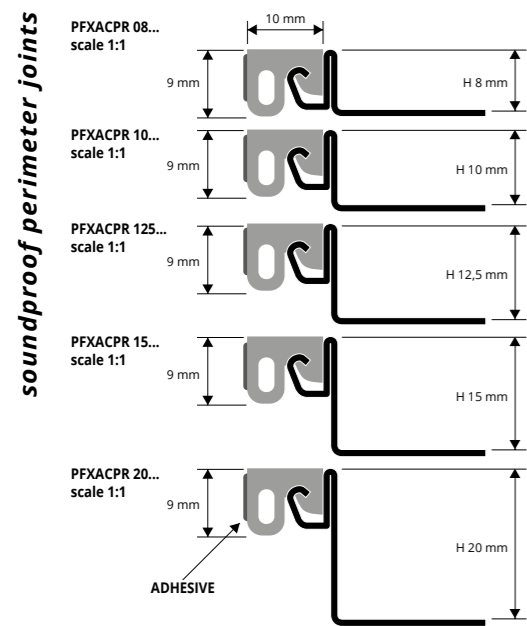

POLISHED STAINLESS STEEL AISI 304/1.4301-V2A
+ VINYL RESIN / RUBBER INSERT
bar length 2,5 lm - pack. 20 PZ - 50 lm

Article	H mm	€/lm	€/Pc
PFXACPR 08...	8	17,61	44,03
PFXACPR 10...	10	17,82	44,55
PFXACPR 125...	12,5	18,41	46,03
PFXACPR 15...	15	19,10	47,75
PFXACPR 20...	20	20,26	50,65

COLOURS



SUITABLE FOR USE IN CONTACT WITH FOODSTUFFS



VINYL RESIN / RUBBER INTERCHANGEABLE INSERT

Article	H mm	€/lm	€/Pc
ISPFXACPR 820...	8-10-12,5-15-20	3,34	8,35

Insert available in the colours: G - N (Beige and Ivory available on demand with a minimum quantity order of 200 pcs). The code of the selected finish must be added to the article code. E.g.: ISPFXACPR 820... (chosen insert colour grey) ISPFXACPR 820G.

COLOURS



ON DEMAND MINIMUM QUANTITY 200 pcs for colour and height

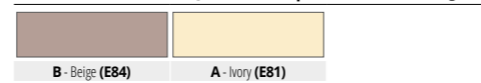

(price and delivery time to be agreed)

PROFLEX OT

NATURAL BRASS
+ VINYL RESIN / RUBBER INSERT

PROFLEX OT is an expansion joint in natural brass with the interchangeable PVC/rubber insert. It is available in black, grey, beige or ivory and serves to fabricate expansion joints for ceramic tile, marble or granite floors and any floor laid with glue/adhesive between 8 and 20 mm thick. The special structure of the joint is designed to protect the corners of the tiles and its high strength withstands frequent pedestrian and vehicular (lift trucks, pallet trucks, cars) traffic. The joint must be placed level with or 0.5-1 mm below the floor level, never above. Lay the joints according with the standards in force. HIGH RESISTANCE TO HEAVY LOADS AND TO FREQUENT PALLET TRUCK AND LIFT TRUCK TRAFFIC.



NATURAL BRASS + VINYL RESIN / RUBBER INSERT
bar length 2,5 lm - pack. 10 Pcs - 25 lm

Article	H mm	€/lm	€/Pc
PFXOT 08...	8	25,44	63,60
PFXOT 10...	10	26,66	66,65
PFXOT 125...	12,5	28,14	70,35
PFXOT 15...	15	29,83	74,58
PFXOT 20...	20	32,74	81,85
PFXOT 30...	30	35,23	88,08

Insert available in the colours: G - N (Beige and Ivory available on demand with a minimum quantity order of 200 pcs). The code of the selected finish must be added to the article code. E.g.: PFXOT 08... (chosen insert colour grey) PFXOT 08G.

COLOURS



VINYL RESIN/RUBBER INSERT
bar length 2,5 lm - pack. 40 Pcs - 100 lm

Article	L x H mm	€/lm	€/Pc
IGCN (black)	14 X 6	3,85	9,63
IGCG (gray)	14 X 6	3,85	9,63
IGCB (beige)	14 X 6	3,85	9,63
IGCA (ivory)	14 X 6	3,85	9,63

ON DEMAND MINIMUM QUANTITY 200 pcs for colour and height

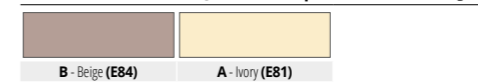

(price and delivery time to be agreed)

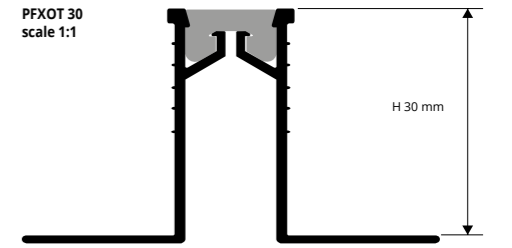

EXAMPLES AND INSTRUCTIONS FOR LAYING METHODS

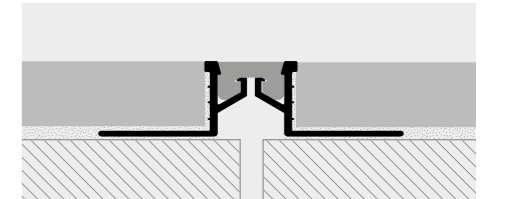

1. Choose the PROFLEX OT with the same height as the thickness of the floor (tile) also choosing the colour of the insert. 2. Using a notched spreader apply the adhesive in the point where the joint will be laid. 3. Lay the PROFLEX OT with the punched flanges in the adhesive (we recommend the expansion joint being laid in line with the joint in the screed/floor rough). 4. Lay the tiles, aligning them with and adjoining the upper edge of the profile (the joint must always be 0.5-1mm lower than the tile, never above). Always place the uncut side of the tile against the profile. 5. Use sealant to fill any spaces between the tile and the PROFLEX OT joint.

PROFLEX AL

NATURAL ALUMINIUM
+ VINYL RESIN / RUBBER INSERT

PROFLEX AL is an expansion joint in natural aluminium with the PVC/rubber insert. It is available in black, grey, beige or ivory and serves to fabricate expansion joints for ceramic tile, marble or granite floors and any floor laid with glue/adhesive between 8 and 20 mm thick. The special structure of the joint is designed to protect the corners of the tiles and its high strength withstands frequent pedestrian and vehicular (lift trucks, pallet trucks, cars) traffic. The joint must be placed level with or 0.5-1 mm below the floor level, never above. Lay the joints according with the standards in force. HIGH RESISTANCE TO HEAVY LOADS AND TO FREQUENT PALLET TRUCK AND LIFT TRUCK TRAFFIC.



NATURAL ALUMINIUM + VINYL RESIN / RUBBER INSERT
bar length 2,5 lm - pack. 20 Pcs - 50 lm

Article	H mm	€/lm	€/Pc
PFXAL 08...	8	11,42	28,55
PFXAL 10...	10	11,64	29,10
PFXAL 125...	12,5	11,96	29,90
PFXAL 15...	15	12,64	31,60
PFXAL 20...	20	13,70	34,25

Insert available in the colours: G - N (Beige and Ivory available on demand with a minimum quantity order of 200 pcs). The code of the selected finish must be added to the article code. E.g.: PFXAL 08... (chosen insert colour grey) PFXAL 08G.

COLOURS



LAYING INSTRUCTIONS

1. Choose "PROFLEXAL" according to the tile thickness and desired colour. 2. Cut "PROFLEXAL" to the desired length and apply the adhesive on the support where the profile will be laid. 3. Place the joint exactly over the screed joint and press the anchoring flange into the adhesive. 4. Lay the tiles aligning them with the profile leaving a 2 mm joint. After laying the joint should be 0,5 mm below the floor covering surface. Remove immediately all the remains of adhesive from the surface of the profile. 5. Fill the joints between the profile and the tiles with grout, in order to avoid water stagnation. Remove immediately all the remains of grout from the surface of the profile.



VINYL RESIN/RUBBER INSERT
bar length 2,5 lm - pack. 40 Pcs - 100 lm

Article	L x H mm	€/lm	€/Pc
IGCN (black)	14 X 6	3,85	9,63
IGCG (gray)	14 X 6	3,85	9,63
IGCB (beige)	14 X 6	3,85	9,63
IGCA (ivory)	14 X 6	3,85	9,63

ON DEMAND MINIMUM QUANTITY 200 pcs for colour and height

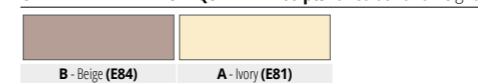

(price and delivery time to be agreed)

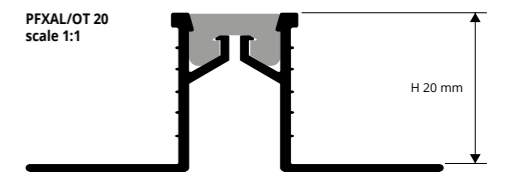
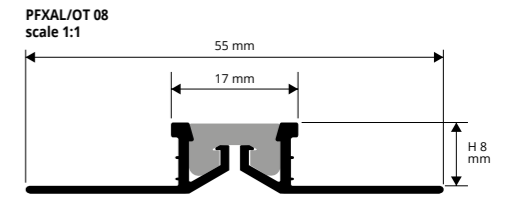

PROFLEX ACN

STAINLESS STEEL AISI 304/1.4301-V2A

PROFLEX ACN is a movement joint suitable for vehicular traffic composed by two interlocked sliding stainless steel profiles. The two stainless steel profiles have punched flanges which guarantee a perfect fixing to the support and a correct movement. PROFLEX ACN stainless steel is suitable for all areas with heavy chemical and mechanical stress. Lay the joints according to UNI 11493-1.

POLISHED STAINLESS STEEL AISI 304/1.4301-V2A

bar length 2,5 lm - pack. 20 Pcs - 50 lm

Article	H mm	€/lm	€/Pc
PFXACN 08	8	28,00	70,00
PFXACN 10	10	28,80	72,00
PFXACN 11	11	29,25	73,13
PFXACN 125	12,5	30,00	75,00
PFXACN 15	15	31,25	78,13
PFXACN 20	20	32,50	81,25
PFXACN 25	25	33,75	84,38
PFXACN 30	30	35,00	87,50

COLOURS

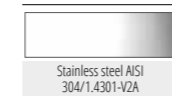

1. Choose the PROFLEX ACN with the same height as the thickness of the floor (tile).
2. Using a notched spreader apply the adhesive in the point where the joint will be laid.
3. Lay the PROFLEX ACN with the punched flanges in the adhesive (we recommend the expansion joint being laid in line with the joint in the screed/floor rough).
4. Lay the tiles, aligning them with and adjoining the upper edge of the profile (the joint must always be 0.5-1mm lower than the tile, never above). Always place the uncut side of the tile against the profile.
5. Use sealant to fill any spaces between the tile and the PROFLEX ACN joint.



EXAMPLES AND INSTRUCTIONS FOR LAYING METHODS

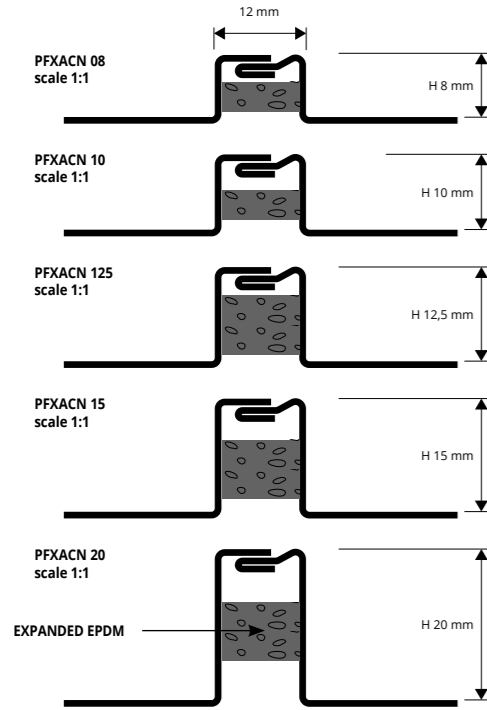
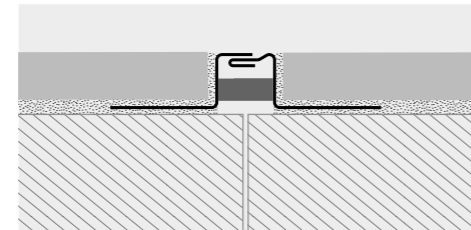

AVAILABLE
H 11mm - PFXACN 11, H 25mm - PFXACN 25, H 30mm - PFXACN 30

PRODILAT is an expansion joint in stainless steel inox AISI 304 / 1.4301 - V2A composed of two counterposed profiles in "L" shape, joined with a vulcanized EPDM which can be polished, available in black and grey colour. The counterposed profile in "L" shape have perforated wings for a perfect bond to the substrate and a correct movement of the joint. The expanding EPDM has a high resistance to mechanical & chemical stress, UV rays, to fungi and bacteria. PRODILAT in stainless steel is suitable to be used in all environments with high mechanical and chemical stress. Lay the joints according to UNI 11493-1 regulation.

PRODILAT

STAINLESS STEEL AISI 304/1.4301-V2A WITH SANDABLE VULCANIZED EPDM



STAINLESS STEEL AISI 304/1.4301-V2A WITH SANDABLE VULCANIZED EPDM - bar length 2,7 lm - pack. 20 Pcs - 54 lm (GCAC 20 - 27 lm)

Article	H mm	€/lm	€/Pc
GCAC 08... (8x10)	8	35,75	96,53
GCAC 10... (10x10)	10	37,23	100,52
GCAC 125... (12,5x10)	12,5	40,30	108,81
GCAC 15... (15x10)	15	42,53	114,83
GCAC 20... (20x10)	20	49,03	132,38

SUITABLE FOR USE IN CONTACT WITH FOODSTUFFS

Possible specks on the surface of the vulcanised rubber are due to the nature of the product itself, they disappear once the laid profile is polished or cleaned. Claims due to these specks will not be taken into consideration.



Insert available in the colours: N - G.
The code of the selected finish must be added to the article code.
E.g.: GCAC 08... (chosen insert colour grey) GCAC 08G.
H 25 / H 30 on demand.

COLOURS

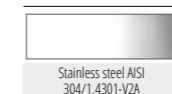

COLOURS (EPDM)

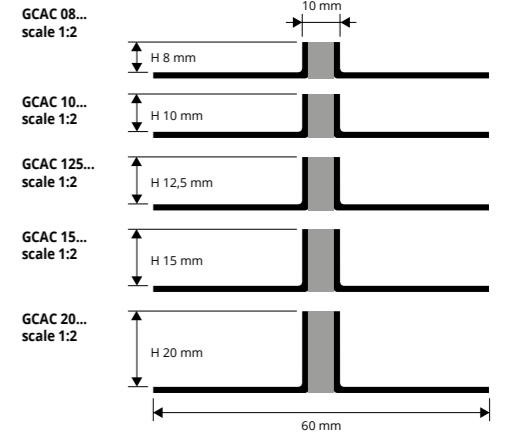

EXAMPLES AND INSTRUCTIONS FOR LAYING METHODS

1. Choose the PRODILAT with the same height as the thickness of the floor (tile) also choosing the colour of the insert.
2. Using a notched spreader apply the adhesive in the point where the joint will be laid.
3. Lay the PRODILAT with the punched flanges in the adhesive (we recommend the expansion joint being laid in line with the joint in the screed/floor rough).
4. Lay the tiles, aligning them with and adjoining the upper edge of the profile (the joint must always be 0.5-1mm lower than the tile, never above). Always place the uncut side of the tile against the profile.
5. Use sealant to fill any spaces between the tile and the PRODILAT.

PROFLEX ALN

NATURAL ALUMINIUM

PROFLEX ALN is a new, natural aluminium expansion joint consisting of two interlocked sliding profiles designed for glued floors. PROFLEX ALN provides elastic expansion joints for various kinds of flooring, such as ceramic, marble, granite, Kerilite or any other flooring material laid with glue/adhesive and having a thickness of 8 to 20 mm. The joint is specially designed to protect the edges of the tiles, and its exceptional strength makes it capable of supporting frequent traffic, both pedestrian and vehicular (forklifts, pallet trucks, automobiles). The joint must be installed at the same level of the floor or 0.5-1 mm lower (never above). Lay the joints according with the standards in force. HIGH RESISTANCE TO LOADS AND TO FREQUENT TRAFFIC OF PALLET TRUCKS AND FORKLIFTS.

EXAMPLES AND INSTRUCTIONS FOR LAYING METHODS

1. Choose the PROFLEX ALN with the same height as the thickness of the floor (tile).
2. Using a notched spreader apply the adhesive in the point where the joint will be laid.
3. Lay the PROFLEX ALN with the punched flanges in the adhesive (we recommend the expansion joint being laid in line with the joint in the screed/floor rough).
4. Lay the tiles, aligning them with and adjoining the upper edge of the profile (the joint must always be 0.5-1mm lower than the tile, never above). Always place the uncut side of the tile against the profile.
5. Use sealant to fill any spaces between the tile and the PROFLEX ALN joint.



NATURAL ALUMINIUM

bar length 2,5 lm - pack. 20 Pcs - 50 lm

Article	H mm	€/lm	€/Pc
PFXALN 08	8	12,27	30,68 *
PFXALN 10	10	12,75	31,88
PFXALN 125	12,5	13,17	32,93
PFXALN 15	15	13,80	34,50
PFXALN 20	20	14,76	36,90

COLOURS

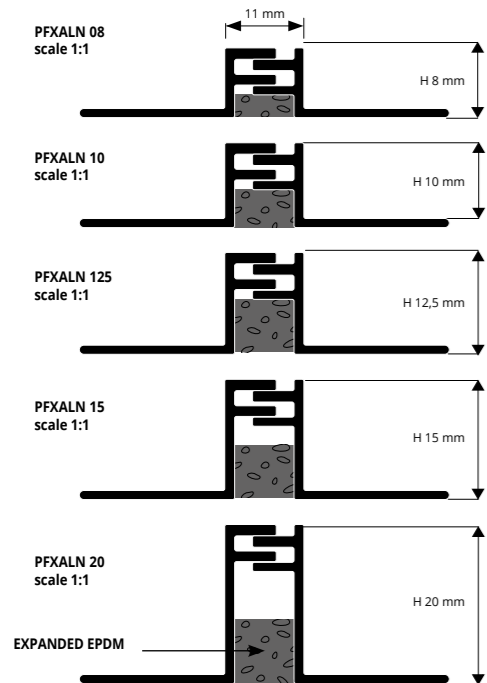

EXPANDED EPDM

PRODILAT is an expansion joint in natural aluminium composed of two counterposed profiles in "L" shape, joined with a vulcanized EPDM which can be polished, available in black and grey colour. The counterposed profile in "L" shape have perforated wings for a perfect bond to the substrate and a correct movement of the joint. The expanding EPDM has a high resistance to mechanical & chemical stress, UV rays, to fungi and bacteria. PRODILAT in aluminium is suitable to be used in all environments with high mechanical and chemical stress. Lay the joints according to UNI 11493-1 regulation.

PRODILAT

ALUMINIUM WITH SANDABLE VULCANIZED EPDM



ALUMINIUM WITH SANDABLE VULCANIZED EPDM

bar length 2,7 lm - pack. 20 Pcs - 54 lm

Article	H mm	€/lm	€/Pc
GCAN 08... (8x10)	8	23,43	63,26
GCAN 10... (10x10)	10	24,23	65,42
GCAN 125... (12,5x10)	12,5	25,76	69,55
GCAN 15... (15x10)	15	27,40	73,98
GCAN 20... (20x10)	20	30,57	82,54

COLOURS



COLOURS (EPDM)



Possible specks on the surface of the vulcanised rubber are due to the nature of the product itself, they disappear once the laid profile is polished or cleaned. Claims due to these specks will not be taken into consideration.



Insert available in the colours: N - G.
The code of the selected finish must be added to the article code.
E.g.: GCAN 08... (chosen insert colour grey) GCAN 08G.
H 25 / H 30 on demand.

EXAMPLES OF LAYING

1. Choose "PRODILAT" according to the desired finish, tile thickness and desired colour.
2. Cut "PRODILAT" to the desired length and apply the adhesive on the support where the profile will be laid.
3. Place the joint exactly over the screed joint and press the anchoring flange into the adhesive.
4. Lay the tiles, aligning them with the profile leaving a 2 mm. joint. After laying the joint should be 0,5 mm below the floor covering surface. Remove immediately all the remains of adhesive from the surface of the profile.
5. Fill the joints between the profile and the tiles with grout, in order to avoid water stagnation. Remove immediately all the remains of grout from the surface of the profile.

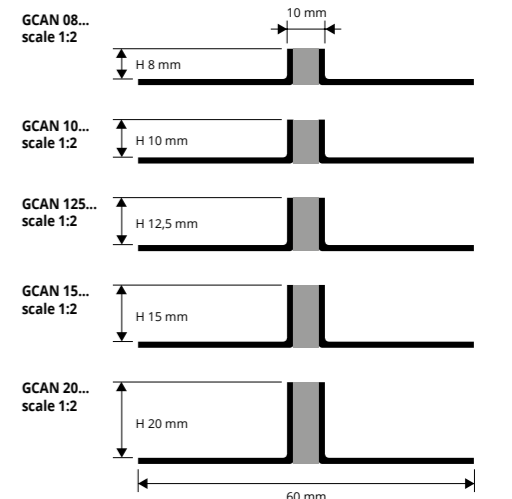

LAYING INSTRUCTIONS

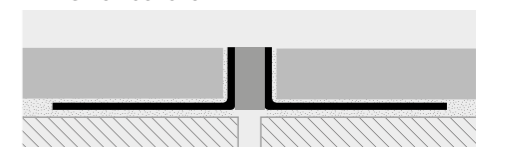

© News 2019

* = Production on demand with minimum quantity of 100 pcs. Delivery time 4/5 weeks. Price to agree

Prices are referred to whole packs, 10% increase for minimum orders of 10 Pcs, 20% increase for orders of less than 10 Pcs.

PROFLEX

NON-TOXIC IMPACT-RESISTANT CO-EXTRUDED VINYL RESIN (PVC)

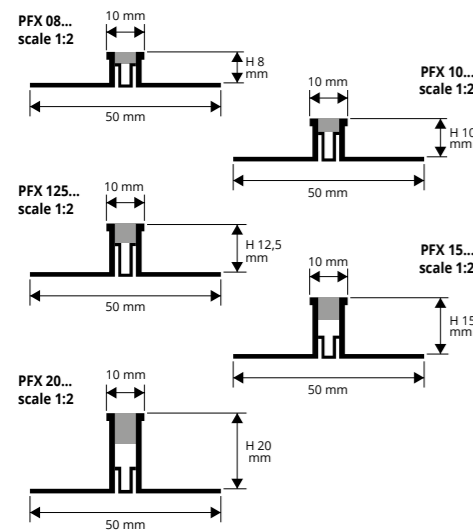

EXAMPLES AND INSTRUCTIONS FOR LAYING METHODS

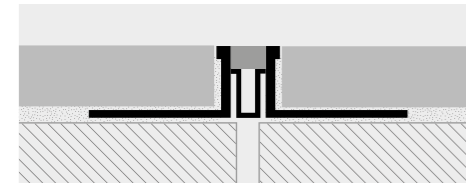

PROFLEX is an expansion joint in PVC with PVC/rubber insert. Available in 3 standard colours, **PROFLEX** serves to fabricate expansion joints for ceramic tile, marble or granite floors and any floor laid with glue/adhesive between 8 and 20 mm thick. The special structure of the joint is designed to protect the corners of the tiles and its high strength withstands frequent pedestrian and vehicular (lift trucks - pallet trucks - cars) traffic. The joint must be placed level with or 0.5-1 mm below the floor level, never above. Lay the joints according with the standards in force.



NON - TOXIC CO-EXTRUDED VINYL RESIN - bar length 2,5 lm pack. 40 Pcs - 100 lm (PFX 15 and PFX 20 - pack. 20 Pcs)

Article	H mm	€/lm	€/Pc
PFX 08...	8	3,22	8,05
PFX 10...	10	3,54	8,85
PFX 125...	12,5	3,86	9,65
PFX 15...	15	4,28	10,70
PFX 20...	20	5,13	12,83



Available in the colours: GS-GT-GL (Beige and ivory available on demand). The code of the selected finish must be added to the article code. E.g.: PFX 08... (chosen colour dark grey) PFX 08GS.

COLOURS



ON DEMAND MINIMUM QUANTITY 200 pcs

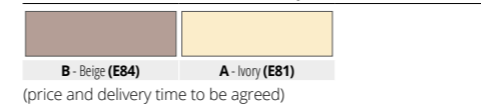

1. Choose the PROFLEX with suitable height for the thickness of the floor.
2. Apply the adhesive onto the area of application of the profile.
3. Lay and align the profile, cut to the necessary length, pressing the perforated flange into the adhesive.
4. Lay the tiles, aligning them so that the top edge of the profile is flush with the tile.
5. Fill the profile/ tile area of contact with adhesive to prevent the accumulation of water in any voids.

PROFLEX 5

NON-TOXIC IMPACT-RESISTANT CO-EXTRUDED VINYL RESIN (PVC)

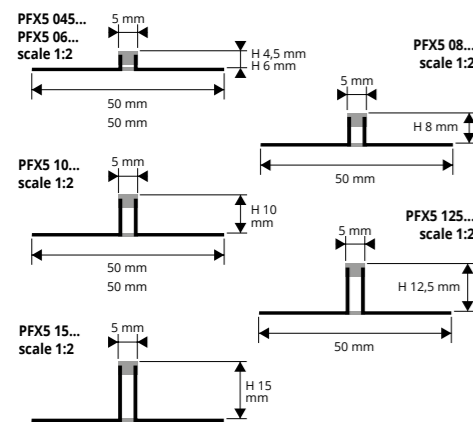

EXAMPLES AND INSTRUCTIONS FOR LAYING METHODS

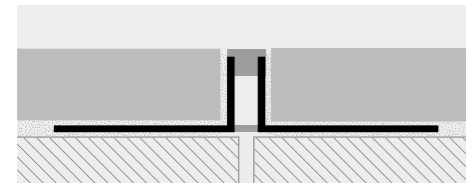

PROFLEX 5 is a range of technical expansion joint profiles for floors laid with glue/adhesive. They are made in non-toxic, impact-resistant, co-extruded PVC with perforated horizontal lateral flanges in rigid PVC while the elastic central part is made in flexible vinyl resin 5 mm in width. They are able to absorb moderate tensile and compressive stress, while being resistant to most chemical agents, to wear and to UV rays. They may be used indoors and outdoors. Thanks to the limited widths, **PROFLEX 5** may be considered a "gap cover" because it blends in with the gaps between tiles. The joint profile must never be placed over a tiled floor and should preferably always be 0.5-1 mm lower. Lay the joints according with the standards in force.



NON - TOXIC CO-EXTRUDED VINYL RESIN - bar length 2,5 lm pack. 40 Pcs - 100 lm (PFX5 15 - pack. 20 Pcs - 50 lm)

Article	H mm	€/lm	€/Pc
PFX5 045...	4,5	2,53	6,33
PFX5 06...	6	2,75	6,88
PFX5 08...	8	2,85	7,13
PFX5 10...	10	3,17	7,93
PFX5 125...	12,5	3,44	8,60
PFX5 15...	15	3,70	9,25



Available in the colours: GS-GL (Beige and ivory available on demand with a minimum quantity order of 200 pcs). The code of the selected finish must be added to the article code. E.g.: PFX5 08... (chosen colour dark grey) PFX5 08GS.

COLOURS



ON DEMAND MINIMUM QUANTITY 200 pcs for colour and height

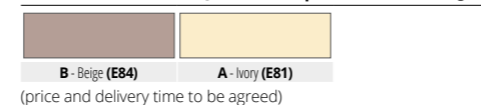

1. Choose the PROFLEX 5 with suitable height for the thickness of the floor.
2. Apply the adhesive onto the area of application of the profile.
3. Lay and align the profile, cut to the necessary length, pressing the perforated flange into the adhesive.
4. Lay the tiles, aligning them so that the top edge of the profile is flush with the tile.
5. Fill the profile/ tile area of contact with adhesive to prevent the accumulation of water in any voids.

PROFLEX 5 PR is a perimeter joint made of coextruded vinyl resin that can be used to connect the floor to the wall lining or the wall lining to doors and windows and/or to any other kind of lining. The 5 mm elastic part (exposed) allows the floor/lining to expand as necessary. **PROFLEX 5 PR** prevents and dampens the propagation of sound waves and the forming of sound bridges. Available in dark grey, light grey, Beige and Ivory, in various heights H 4,5-6-8-10-12,5 mm. Lay the joints according with the standards in force.

PROFLEX 5 PR

NON-TOXIC IMPACT-RESISTANT CO-EXTRUDED VINYL RESIN (PVC)



VINYL RESIN - bar length 2,5 lm - pack. 40 Pcs - 100 lm

Article	H mm	€/lm	€/Pc
PFX5PR 045...	4,5	2,53	6,33
PFX5PR 06...	6	2,75	6,88
PFX5PR 08...	8	2,85	7,13
PFX5PR 10...	10	3,17	7,93
PFX5PR 125...	12,5	3,44	8,60
PFX5PR 15...	15	3,70	9,25

Available in the colours: GS-GL (Beige and ivory available on demand with a minimum quantity order of 200 pcs). The code of the selected finish must be added to the article code. E.g.: PFX5PR 045... (chosen insert colour dark grey) PFX5PR 045GS.

COLOURS



EXAMPLES AND INSTRUCTIONS FOR LAYING METHODS

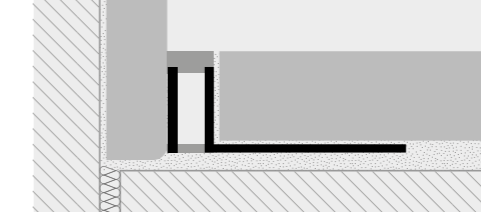

1. Choose the PROFLEX PR with suitable height for the thickness of the floor.
2. Apply the adhesive onto the area of application of the profile.
3. Lay and align the profile, cut to the necessary length, pressing the perforated flange into the adhesive.
4. Lay the tiles, aligning them so that the top edge of the profile is flush with the tile.
5. Fill the profile/ tile area of contact with adhesive to prevent the accumulation of water in any voids.

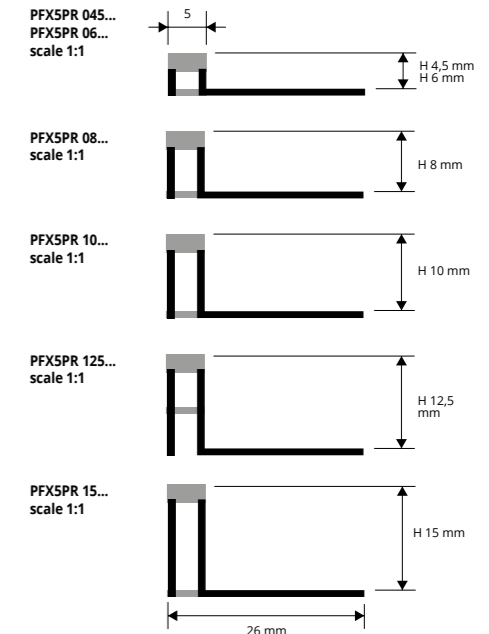

ON DEMAND MINIMUM QUANTITY 200 pcs for colour and height

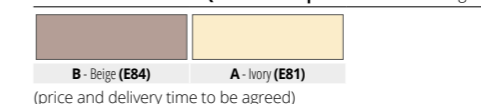

(price and delivery time to be agreed)



* = Production on demand with minimum quantity of 100 pcs. Delivery time 4/5 weeks. Price to agree

Prices are referred to whole packs, 10% increase for minimum orders of 10 Pcs, 20% increase for orders of less than 10 Pcs.

ADHESIVE-LAID JOINTS

CO-EXTRUDED VINYL RESIN

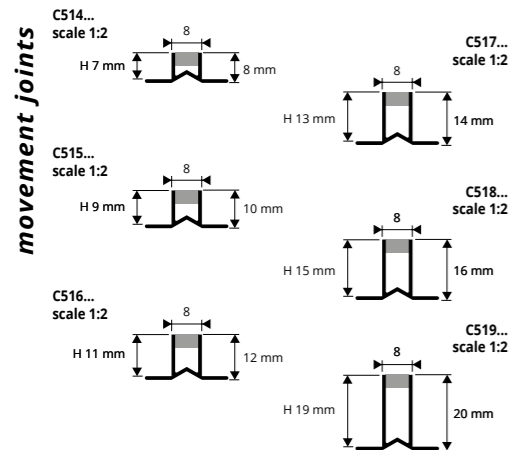

EXAMPLES AND INSTRUCTIONS FOR LAYING METHODS

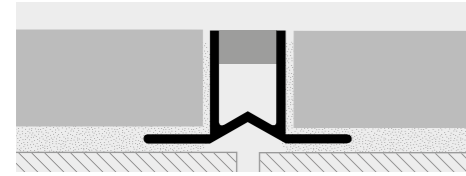

1. Choose the joint in accordance with the colour and thickness of the floor, calculating 0.5-1 mm less for laying the joint, which under no circumstances must protrude.
2. Place the joint over the cut/joint in the screed; if there is none, make a cut of 2/3 the thickness of the screed.
3. Apply the adhesive and lay the joint, pressing it into the glue.
4. Lay the tiles, aligning them with the rigid vertical part of the joint.
5. Using the special glue, fill the gap between the tiles and the profile.

ADHESIVE-LAID MOVEMENT JOINTS are a range of joints in co-extruded vinyl resin with the flanges and vertical supports made in rigid synthetic vinyl resin and the elastic central part in flexible synthetic vinyl resin. The glue-laid joints must be placed at least 0.5-1 mm below the level of the flooring (usually tiles) and never above. Suitable for pedestrian traffic, they absorb compressive and slip stress. Laying modules between 16 and 30 m3 inclusive are recommended and the joint laid in line with the joints in the underlying screed. Available in various colours and heights. Lay the joints according with the standards in force.



CO-EXTRUDED VINYL RESIN

bar length 2,5 lm - pack. 40 Pcs - 100 lm

Article	H mm	€/lm	€/Pc
C514... (8x8)	7	0,83	2,08
C515... (10x8)	9	0,93	2,33
C516... (12x8)	11	1,04	2,60
C517... (14x8)	13	1,14	2,85
C518... (16x8)	15	1,27	3,18
C519... (20x8)	19	1,72	4,30

ARTICLES NOT FOR SALE SINGLY

Available combinations: GS-GT-GL (RT-MT-BIBI-B-A and N available on demand with a minimum quantity order of 400 pcs). The code of the selected colour must be added to the article code. E.g.: C514... (combination chosen colour Dark Grey / Transparent) C514 GT

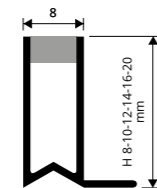

On demand (at same price) also available **WITHOUT FLAP** with a minimum order of 200 pcs. N.B.: specify "WITHOUT FLAP" in order.

MORTAR-LAID JOINTS

POLISHED BRASS - STAINLESS STEEL AISI304/1.4301-V2A
NATURAL ALUMINIUM WITH SANDABLE VULCANIZED EPDM

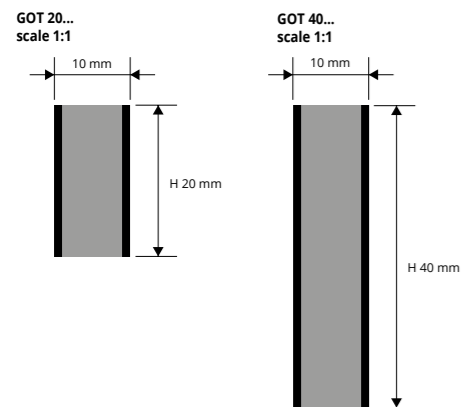

EXAMPLES AND INSTRUCTIONS FOR LAYING METHODS

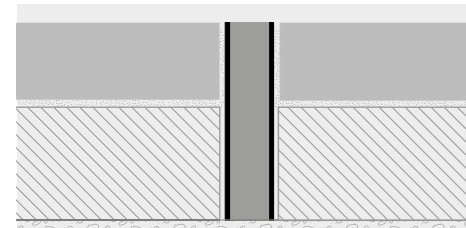

1. Choose the colour and the necessary height of the joint, calculating the thickness of the finished floor and the thickness of the screed.
2. Insert the joint into the screed letting it protrude slightly.
3. Proceed with laying the floor, aligning it with the rigid vertical part of the joint.
4. Complete laying by levelling the joint with the floor.
5. Using the mortar, grout the gap between the tiles and the profile.



POLISHED BRASS WITH SANDABLE VULCANIZED EPDM
bar length 2 lm - pack. 25 Pcs - 50 lm (GOT 40... - 20 lm)

Article	L x H mm	€/lm	€/Pc
GOT 20...	10 X 20	37,72	75,44
GOT 40...	10 X 40	64,65	129,30

On demand, delivery time to be agreed

COLOURS

OL - Polished Brass	AC - Polished Stainless Steel AISI 304/1.4301-V2A	AN - Natural aluminium

COLOURS (EPDM)

N - Black	G - Grey



POLISHED STAINLESS STEEL AISI 304/1.4301-V2A WITH SANDABLE VULCANIZED EPDM
bar length 2 lm - pack. 25 Pcs - 50 lm (GAC 40... - 20 lm)

Article	L x H mm	€/lm	€/Pc
GAC 20...	10 X 20	35,50	71,00
GAC 40...	10 X 40	50,56	101,12

NATURAL ALUMINIUM WITH SANDABLE VULCANIZED EPDM
bar length 2 lm - pack. 25 Pcs - 50 lm (GAL 40... - 40 lm)

Article	L x H mm	€/lm	€/Pc
GAL 20...	10 X 20	30,39	60,78
GAL 40...	10 X 40	46,35	92,70

Insert available in the colours: G - N (White, Ivory and Brown available on demand with a minimum quantity order of 200 pcs). The code of the selected finish must be added to the article code. E.g.: GAC 20... (chosen insert colour grey) GAC 20G.

MORTAR-LAID MOVEMENT JOINTS are a range of joints in co-extruded vinyl resin with the flanges and vertical supports made in rigid synthetic vinyl resin and the elastic central part in flexible synthetic vinyl resin. The mortar-laid joints must be placed at least 0.5-1mm below the level of the ceramic tile-marble-granite floor and never above. Suitable for pedestrian traffic, they absorb compressive and slip stress. Laying modules between 16 and 30 m3 inclusive are recommended and the joint laid in line with the joints in the underlying screed. Available in various colours and heights. Lay the joints according with the standards in force.



CO-EXTRUDED VINYL RESIN
bar length 2,5 lm - pack. 40 Pcs - 100 lm (C513 - pack. 50 lm)

Article	L x H mm	€/lm	€/Pc
C511...	8 X 25	1,31	3,28
C512...	8 X 35	1,52	3,80
C513...	8 X 45	1,91	4,78

ARTICLES NOT FOR SALE SINGLY

Available combinations: GS-GT-GL (RT-MT-BIBI-B-A and N available on demand with a minimum quantity order of 400 pcs). The code of the selected colour must be added to the article code. E.g.: C511... (combination chosen colour dark grey/transparent) C511 GT.

COLOURS

ON DEMAND MINIMUM QUANTITY 400 PCS for colour and height

GS - Dark grey for rigid and flexible part	GT - Dark grey for rigid part / Transparent for flexible part	GL - Light grey for rigid and flexible part

RT - Red for rigid part / Transparent for flexible part	MT - Brown for rigid part / Transparent for flexible part	BIBI - White for rigid and flexible part

B - Beige (E84)	A - Ivory (E81)	N - Black for rigid and flexible part

(price and delivery time to be agreed)

EXAMPLES OF LAYING

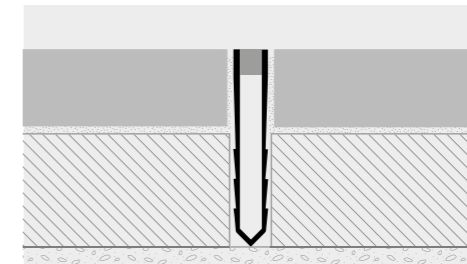

MORTAR-LAID JOINTS

CO-EXTRUDED VINYL RESIN

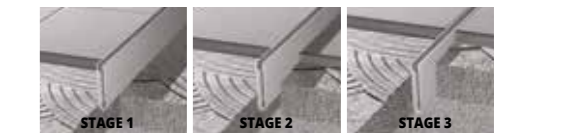
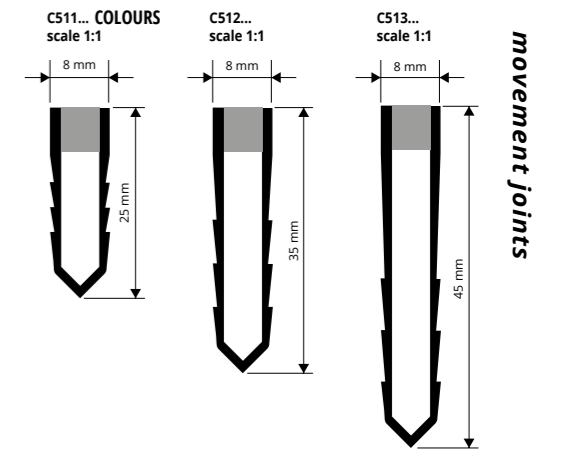

1. Choose the colour and the necessary height of the joint, calculating the thickness of the finished floor and the thickness of the screed.
2. Insert the joint into the screed letting it protrude slightly (stage 1-2-3).
3. Proceed with laying the floor, aligning it with the rigid vertical part of the joint.
4. Complete laying by levelling the joint with the floor.
5. Using the mortar, grout the gap between the tiles and the profile.

This **DOUBLE SILICONE JOINT** is a co-extruded profile in hard and soft PVC. The double internal silicone provides a high degree of resistance to any type of compressive stress, heavy loads and foot traffic. The extension is designed to lengthen the joint, extending it to the total depth of auxiliary or insulation castings as required. Lay the joints according with the standards in force.



CO-EXTRUDED VINYL RESIN (PVC) WITH DOUBLE SILICONE
bar length 2,5 lm - pack. 40 Pcs - 100 lm (GDSP 43 - CONF. 50 lm)

Article	L x H mm	€/lm	€/Pc
GDSP 43...	10 X 43	3,32	8,30
GDS 23...	10 X 25	1,84	4,60
GP 20...	8 X 20	1,19	2,98

ARTICLES NOT FOR SALE SINGLY

Available combinations: GS - GT - GL. The code of the selected colour must be added to the article code. E.g.: GDSP 43... (combination chosen colour dark grey/transparent) GDSP 43GT.

COLOURS

GS - Dark grey for rigid and flexible part	GT - Dark grey for rigid part / Transparent for flexible part	GL - Light grey for rigid and flexible part

EXAMPLES AND INSTRUCTIONS FOR LAYING METHODS

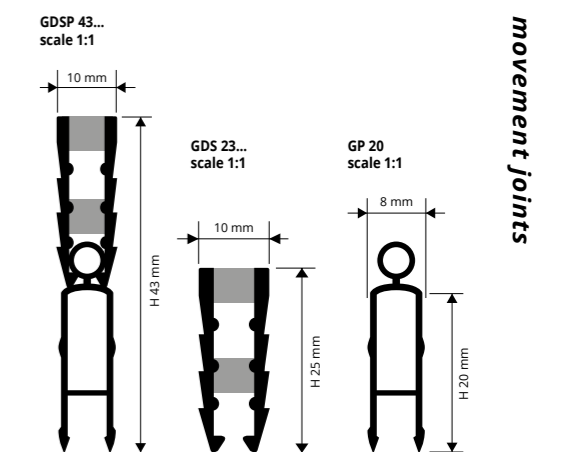
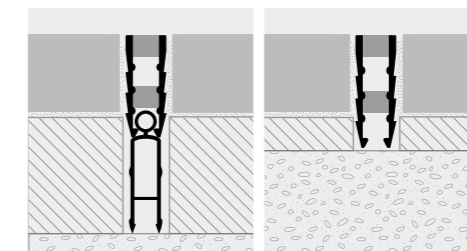

1. Choose the colour and the necessary height of the joint, calculating the thickness of the finished floor and the thickness of the screed.
2. Insert the joint into the screed letting it protrude slightly.
3. Proceed with laying the floor, aligning it with the rigid vertical part of the joint.
4. Complete laying by levelling the joint with the floor.
5. Using the mortar, grout the gap between the tiles and the profile.

MORTAR LAYING FULL JOINT

CO-EXTRUDED VINYL RESIN (PVC) WITH FULL SILICONE

FULL SILICONE JOINT is a co-extruded profile in hard and soft PVC. The double internal silicone provides a high degree of resistance to any type of compressive stress, heavy loads and foot traffic. The extension is designed to lengthen the joint, extending it to the total depth of auxiliary or insulation castings as required. Lay the joints according with the standards in force.

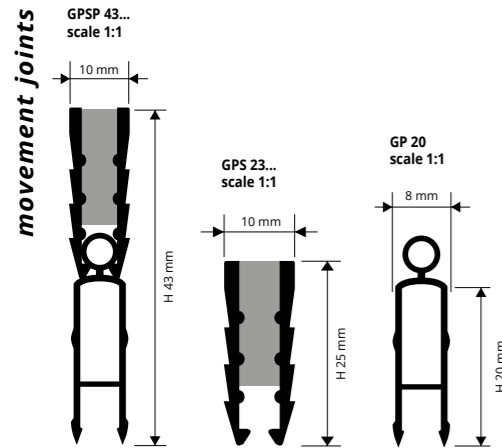

CO-EXTRUDED VINYL RESIN (PVC) WITH FULL SILICONE
bar length 2,5 lm - pack. 40 Pcs - 100 lm

Article	L x H mm	€/lm	€/Pc
GPSP 43...	10 x 43	4,44	11,10 *
GPS 23...	10 x 25	2,65	6,63
GP 20	8 x 20	1,19	2,98

ARTICLES NOT FOR SALE SINGLY

The code of the selected colour must be added to the article code.
E.g.: GPSP 43... (combination chosen colour dark grey/transparent) GPSP 43GT.

1. Choose the colour and the necessary height of the joint, calculating the thickness of the finished floor and the thickness of the screed.
2. Insert the joint into the screed letting it protrude slightly.
3. Proceed with laying the floor, aligning it with the rigid vertical part of the joint.
4. Complete laying by levelling the joint with the floor.
5. Using the mortar, grout the gap between the tiles and the profile.



COLOURS

GS - Dark grey for rigid and flexible part	GT - Dark grey for rigid part / Transparent for flexible part	GL - Light grey for rigid and flexible part
--	---	---

EXAMPLES AND INSTRUCTIONS FOR LAYING METHODS

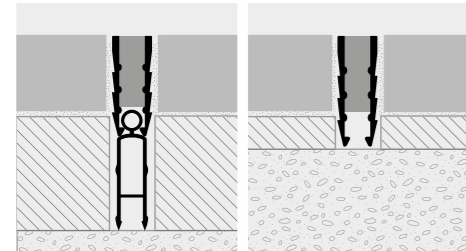

PROFLEX 25

NON-TOXIC IMPACT-RESISTANT CO-EXTRUDED VINYL RESIN

PROFLEX 25 H 25 mm is a new expansion joint made of coextruded vinyl resin available in two standard colours - dark grey (GS) and light grey (GL). PROFLEX 25 H 25 mm provides elastic expansion joints for various kinds of flooring, such as marble or granite, and especially floors made with Sasso Italia. The new decorative indoor and outdoor flooring also known as SASSO ITALIA is approx. 25 mm thick and laid over a 10-20 mm base of cement/concrete. This kind of floor needs an expansion/control joint every 16-30 m³ of material to avoid cracking caused by the floor's expansion. PROFLEX H 25 mm lets you place a GP 20 EXTENSION JOINT at the bottom in order to apply/lay the joint inside the concrete base. It can withstand the frequent passage of pedestrians and vehicles (forklifts, pallet trucks, automobiles). The joint must be installed at the same level of the floor or 0.5-1 mm lower (never above). Lay the joints according with the standards in force. HIGH RESISTANCE TO LOADS AND TO FREQUENT TRAFFIC OF PALLET TRUCKS AND FORKLIFTS.

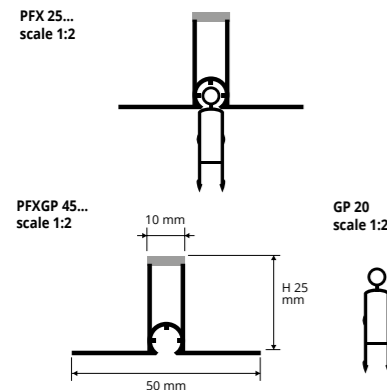

CO-EXTRUDED VINYL RESIN
bar length 2,5 lm - pack. 20 Pcs - 50 lm

Article	H mm	€/lm	€/Pc
PFXGP 45... (Assembled item)	45	8,78	21,95 *
PFX 25...	25	6,72	16,80
GP 20	20	1,19	2,98

The code of the selected colour must be added to the article code.
E.g.: PFX 25... (chosen colour dark grey) PFX 25GS.



COLOURS

GS - Dark grey for rigid and flexible part	GL - Light grey for rigid and flexible part
--	---

EXAMPLES AND INSTRUCTIONS FOR LAYING METHODS

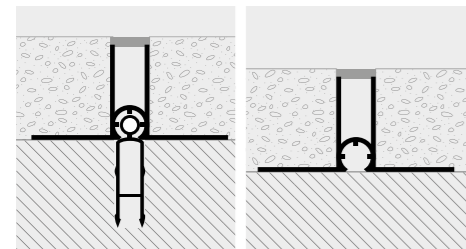

1. Choose the colour of the joint. **1a:** For the version with the extension, insert it onto the fresh cement base leaving the cylindrical part out, for subsequent fitting with PROFLEX 25. **2.** Place and fix with screws/nails to the cement floor and snap the PROFLEX 25 into protruding extension. **3.** Begin laying the floor from the inside, near the joint aligning it with the edges. **4.** Finish laying the floor by levelling the joint with the floor. **5.** Plaster the gap between floor and joint with specific mortar.

PROEXPAN 115-130-190-210 is a range of structural expansion joints in natural aluminium with knurled flat surface and a black or grey synthetic rubber insert. Made to withstand vertical, horizontal and transversal structural movements due to compressive and tensile stress in large buildings or complexes. The joint is laid on existing surfaces, also vertically, over the void between the two semi-detached surfaces of the same building or between two bays. It withstands frequent pedestrian traffic and also vehicles with rubber tyres that can load to 700 kgs. (PENF 190-210)

PROEXPAN 115-130-190-210

NATURAL ALUMINIUM + VINYL RESIN / RUBBER INSERT



NATURAL ALUMINIUM + VINYL RESIN / RUBBER INSERT
bar length 3 lm - pack. 10 Pcs - 30 lm

Article	LxHxLa mm	€/lm	€/Pc
PENF 115...	21 x 12 x 115	30,92	92,76
PENF 130...	38 x 12 x 128	33,64	100,92

NATURAL ALUMINIUM + NEOPRENE INSERT
bar length 3 lm - pack. 10 Pcs - 30 lm

Article	LxHxLa mm	€/lm	€/Pc
PENF 190N (black)	65 x 19 x 185	69,29	207,87
PENF 210... (black or gray)	90 x 19 x 210	111,60	334,80 *

Movement mm: -10/+16 (PENF 190N) -15/+10 (PENF 210...). Available in the colours: G - N (PENF 190N excluded). The code of the selected finish must be added to the article code. E.g.: PENF 130... (chosen insert colour grey) PENF 130G.

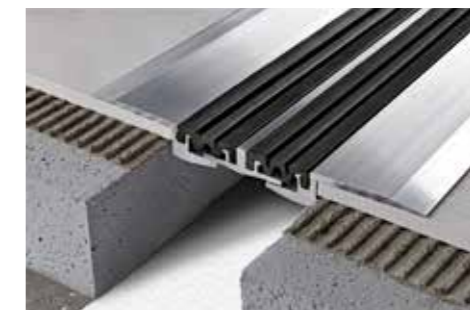

INTERCHANGEABLE INSERT IN VINYL RESIN/RUBBER INSERT BLACK OR GREY - bar length 3 lm - pack. 10 Pcs - 30 lm

Article	L mm	€/lm	€/Pc
IPEN 20...	20	5,68	17,04
IPEN 40...	35	8,21	24,63

INTERCHANGEABLE NEOPRENE INSERT BLACK OR GREY - bar length 4 lm - pack. 10 Pcs - 40 lm

Article	L mm	€/lm	€/Pc
IPEN 65N (black)	65	15,87	63,48
IPEN 452... (black or gray)	45 x 2 Pcs	24,33	97,32

Insert available in the colours: G - N (IPEN 65N excluded). The code of the selected finish must be added to the article code. E.g.: IPEN 20... (chosen insert colour grey) IPEN 20G.

Due to the nature of the product itself, natural aluminium, and its specific use on the floor as technical joint with no decorative role, light scratches on its surface will not be accepted for claims.

INSERT COLOURS

N - Black (RAL 9005)	G - Grey (RAL 7035)
----------------------	---------------------

ON DEMAND - MINIMUM QUANTITY 100 lm ONLY FOR: PENF 115, PENF 130

B - Beige (E84)	A - Ivory (E81)
-----------------	-----------------

(price and delivery time to be agreed)

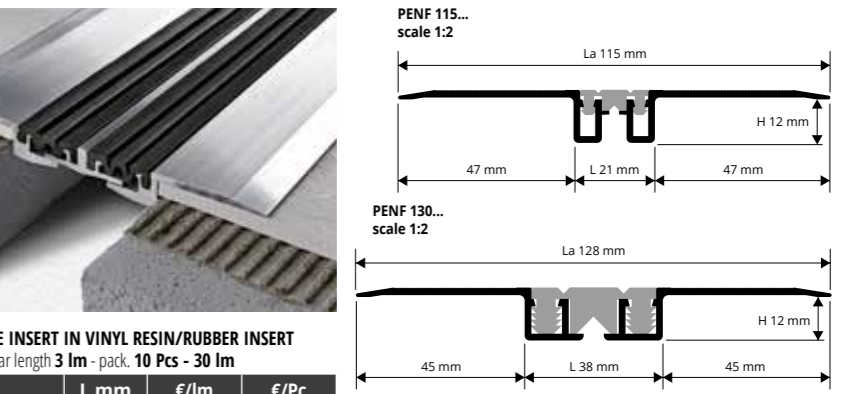

EXAMPLES AND INSTRUCTIONS FOR LAYING METHODS

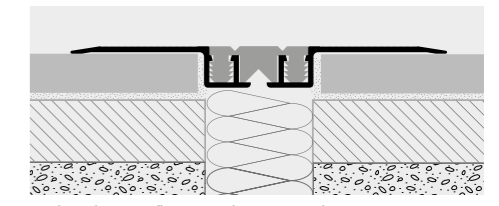

- Fix the side wings/flanges in aluminium with:
1. Screws and screw anchors at 20cm intervals along both sides of the whole joint
 2. Two-pack epoxy adhesive or with strong fast-setting silicone.

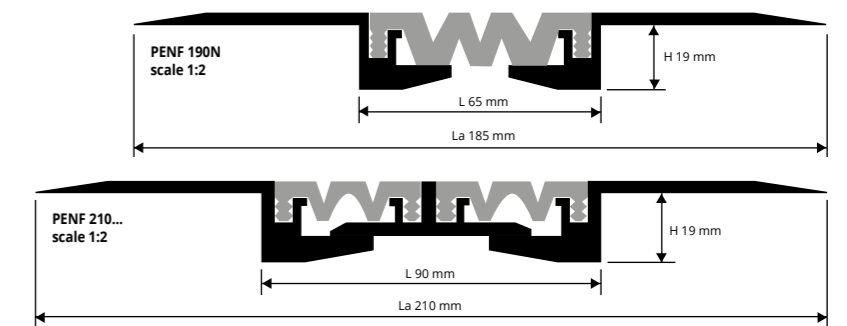

ANGLES BAR / WALL

NATURAL ALUMINIUM + NEOPRENE INSERT

ANGLE BAR NATURAL ALUMINIUM + NEOPRENE INSERT
bar length 3 lm - pack. 10 Pcs - 30 lm

Article	LxHxLa mm	€/lm	€/Pc
PENFP 190N (black)	65 x 19 x 125	69,29	207,87 *
PENFP 210... (black or gray)	90 x 19 x 150	111,60	334,80 *

INTERCHANGEABLE BLACK OR GREY VINYL RESIN/RUBBER INSERT
bar length 3 lm - pack. 10 Pcs - 30 lm

Article	L mm	€/lm	€/Pc
IPEN 65N (black)	65	15,87	47,61
IPEN 452... (black or gray)	45 x 2 Pz	24,33	72,99

Available in the colours: G - N.
The code of the selected finish must be added to the article code. E.g.: PENFP 210... (chosen insert colour grey) PENFP 210G.

PRODUCT SUPPLIED NOT ASSEMBLED

Due to the nature of the product itself, natural aluminium, and its specific use on the floor as technical joint with no decorative role, light scratches on its surface will not be accepted for claims.

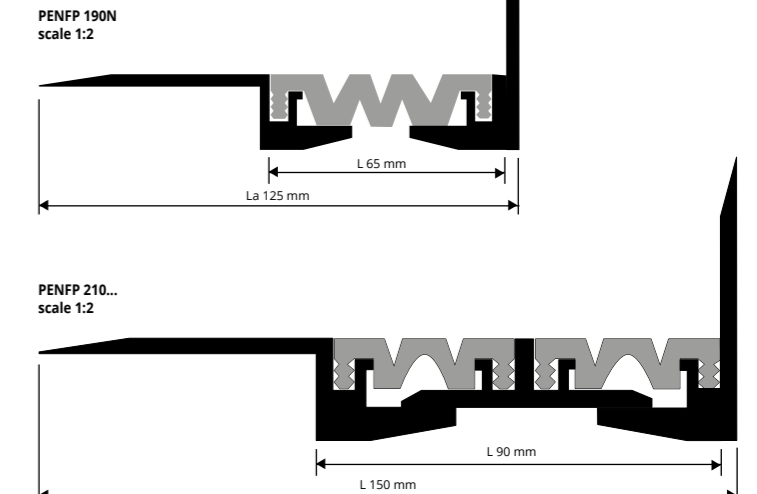

* = Production on demand with minimum quantity of 100 pcs. Delivery time 4/5 weeks. Price to agree

Prices are referred to whole packs, 10% increase for minimum orders of 10 Pcs, 20% increase for orders of less than 10 Pcs.

* = Production on demand with minimum quantity of 100 pcs. Delivery time 4/5 weeks. Price to agree

Prices are referred to whole packs, 10% increase for minimum orders of 10 Pcs, 20% increase for orders of less than 10 Pcs.

PROEXPAN H20 PROEXPAN H40

NATURAL ALUMINIUM
+ VINYL RESIN / RUBBER INSERT

PROEXPAN H20 - H40 is a range of professional structural joints for floors laid on mortar bed (PEN H20) and (PEN H 40). They are made with a punched aluminium base and a vinyl rubber insert available in black or grey. PROEXPAN H20 - H40 profiles for laying with mortar must have the flanges fixed to the substrate by screws and screw anchors (approx. every 30 cm).

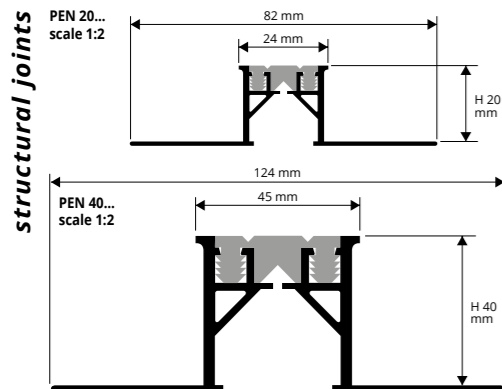

EXAMPLES AND INSTRUCTIONS FOR LAYING METHODS

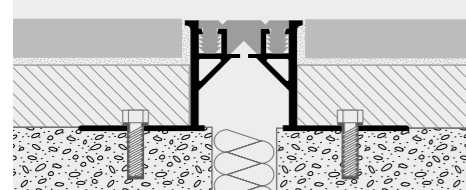

1. Choose the expansion joint with suitable height for the thickness of the floor and the screed/floor rough and choose the colour of the insert. 2. Fix the punched flanges to the substrate using screws and screw anchors, calculating the fixing points at 30cm intervals on both sides. 3. Make the screed over the punched flanges of the structural or expansion joint, calculating the thickness of the final floor, and then lay the floor as normal.



INSERT COLOURS

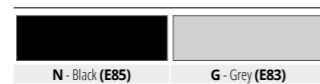

ON DEMAND - MINIMUM QUANTITY 300 LM
(price and delivery time to be agreed)

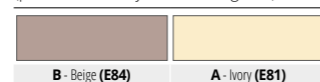

NATURAL ALUMINIUM + VINYL RESIN / RUBBER INSERT bar length 3 lm - pack. 5 Pcs - 15 lm

Article	HxL mm	€/lm	€/Pc
PEN 20...	20 x 24	44,85	134,55
PEN 40...	40 x 45	59,97	179,91

NATURAL ALUMINIUM ANGLE BAR / WALL + VINYL RESIN / RUBBER INSERT - bar length 3 lm - pack. 5 Pcs - 15 lm

Article	HxL mm	€/lm	€/Pc
PENP 20...	20 x 24	44,85	134,55 *
PENP 40...	40 x 45	59,97	179,91 *

Available in the colours: G - N (Beige and Ivory available on demand with a minimum quantity order of 300 lm).
The code of the selected finish must be added to the article code.
E.g.: PEN 20... (chosen insert colour grey) PEN 20G.

GDA 25 GDA 35

NATURAL ALUMINIUM
+ NEOPRENE INSERT

GDA 25 - GDA 35 is a range of professional structural joints for floors laid on mortar bed. They are made with a punched aluminium base and a vinyl rubber insert available in black or grey. It withstands traffic of vehicles with tyreload to 700 kgs and also trucks with maximum tyreload to 1000 kgs.

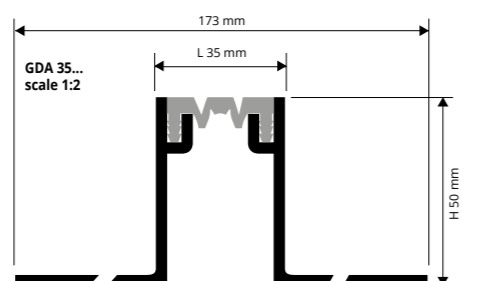
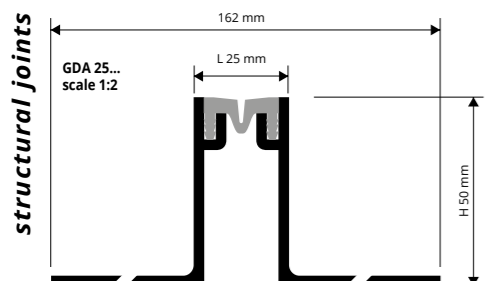

1. Choose the colour of the joint. 2. Fix the punched flanges to the substrate using screws and screw anchors, calculating the fixing points at 30cm intervals on both sides. 3. Make the screed over the punched flanges of the structural or expansion joint, calculating the thickness of the final floor, and then lay the floor as normal. 4. Using the special glue, fill the gap between the tiles and the profile.

INSERT COLOURS

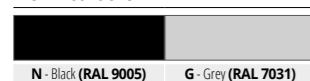

ON DEMAND

On demand min. quantity 400 lm - GDA 25/ GDAP 25
On demand min. quantity 300 lm - GDA 35/ GDAP 35
(price and delivery time to be agreed).

A - Ivory (E81)



NATURAL ALUMINIUM + NEOPRENE INSERT bar length 3 lm

Article	HxL mm	€/lm	€/Pc
GDA 25...	50 x 25	50,78	152,34 *
GDA 35...	50 x 35	57,12	171,36 *

Movement mm: +/- 5.
Insert in smooth neoprene on demand.

NATURAL ALUMINIUM ANGLE BAR / WALL + NEOPRENE INSERT bar length 3 lm

Article	HxL mm	€/lm	€/Pc
GDAP 25...	50 x 25	50,78	152,34 *
GDAP 35...	50 x 35	57,12	171,36 *

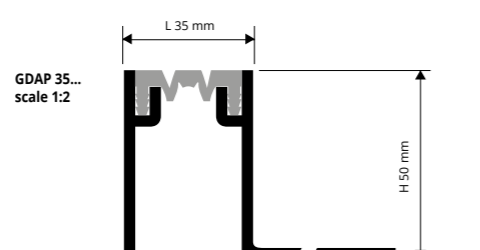
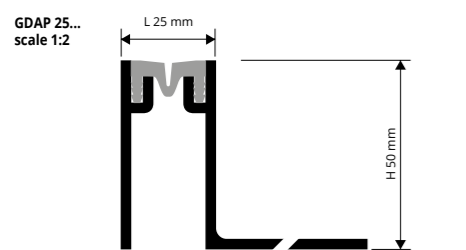

GDA 55

ALUMINIUM
+ NEOPRENE INSERT

GDA 55 is a structural joint for floors, 35, 50 and 80 mm, in good quality natural aluminium with the interchangeable neoprene insert allowing the joint to expand and contract. Visible thickness 55 mm (GDA 55), bar length 3 lm. Black or Grey insert. Bear weights of cars, with the wheel loads up to 650 kg and trucks with a maximum load of 1000 kg on the wheel.



ALUMINIUM + BLACK / GREY NEOPRENE INSERT bar length 3 lm

Article	L x H x L1 mm	€/lm	€/Pc
GDA 5535...	55 x 35 x 155	62,94	188,82
GDA 5550...	55 x 50 x 155	72,46	217,38 *
GDA 5580...	55 x 80 x 155	102,08	306,24 *

Movement mm: +/- 10
Available in the colours: N - G.
The code of the selected finish must be added to the article code.
E.g.: GDA 5535... (chosen insert colour black) GDA 5535N

Insert in smooth neoprene on demand.

ANGLES BAR ALUMINIUM + BLACK NEOPRENE INSERT bar length 3 lm

Article	L x H x L1 mm	€/lm	€/Pc
GDAP 5535	55 x 35 x 105	62,94	188,82 *
GDAP 5550	55 x 50 x 105	72,46	217,38 *
GDAP 5580	55 x 80 x 105	102,08	306,24 *

Insert in smooth neoprene on demand.

COLOURS

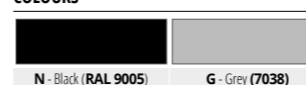

EXAMPLES AND INSTRUCTIONS FOR LAYING METHODS

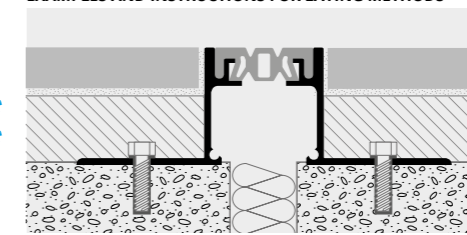

1. Choose the expansion joint with suitable height for the thickness of the floor and the screed/floor rough and choose the colour of the insert. 2. Fix the punched flanges to the substrate using screws and screw anchors, calculating the fixing points at 30cm intervals on both sides. 3. Make the screed over the punched flanges of the structural or expansion joint, calculating the thickness of the final floor, and then lay the floor as normal.

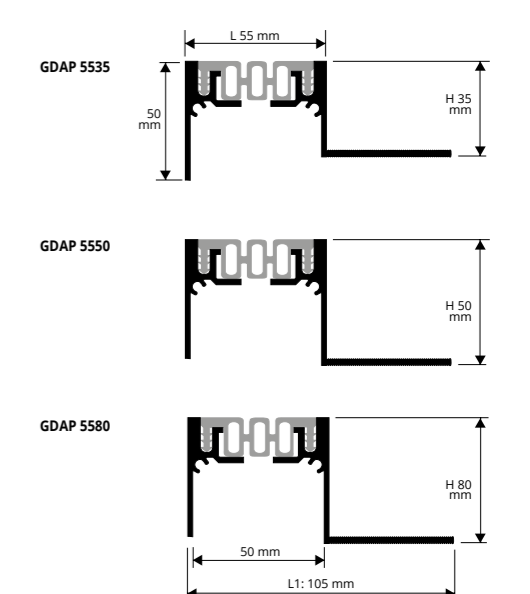
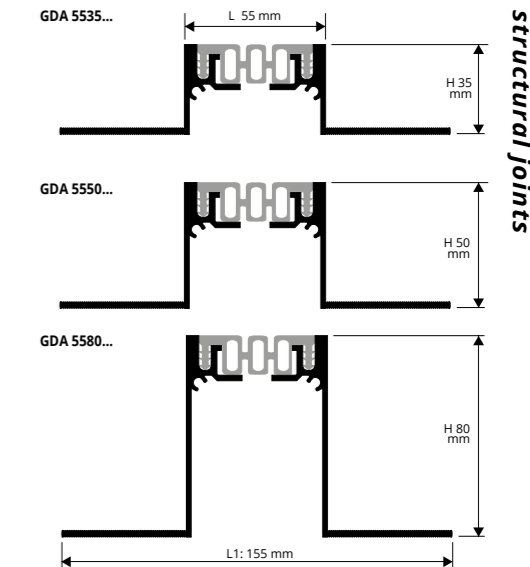

FIREPROOF CORD

MINERAL WOOL AND FIBREGLASS

FIREPROOF GLUE FOR CORD FIXING

Article	Pack. Kg	€/Kg	€/Pack.
CIC 014	1,4	40,73	57,02 *
CIC 7	7	21,79	152,53 *

The delivery of the test certificate depends on the use of silicate glue for the fixing of the same.
The cord is certified in accordance with the new European Standard EN 13501-2.
Consumption of sealant is of about 50 g per linear metre of cord.

FIREPROOF CORD - Diameter 20 - 60 mm

Article	Ø mm	lm Roll	€/lm	€/Roll
CDT 20	20	30	8,99	269,70 *
CDT 30	30	30	9,52	285,60 *
CDT 40	40	30	13,75	412,50 *
CDT 50	50	25	14,81	370,25 *
CDT 60	60	25	17,46	436,50 *



GNS 20 GNS 50

NATURAL ALUMINIUM

Structural joint **GNS 20 - GNS 50** is in good quality natural aluminium with neoprene in the lower central part and another aluminium profile in the upper visible part. It withstands heavy loads and frequent traffic of vehicles with a total truckload of 8 kgs/mm². Bar length 3 m, visible head width 30 mm.

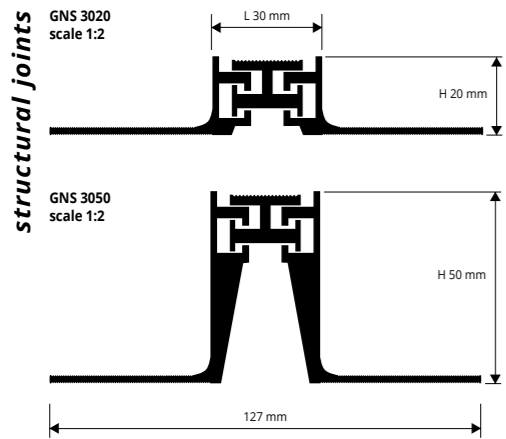

NATURAL ALUMINIUM
bar length 3 lm

Article	L x H mm	€/lm	€/Pc
GNS 3020	30 x 20	62,41	187,23 *
GNS 3050	30 x 50	74,05	222,15 *

Movement mm: +/- 3

EXAMPLES AND INSTRUCTIONS FOR LAYING METHODS

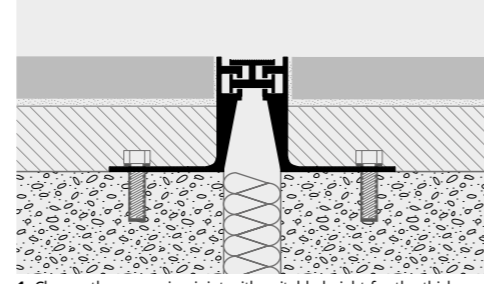

1. Choose the expansion joint with suitable height for the thickness of the floor and the screed/floor rough and choose the colour of the insert. 2. Fix the punched flanges to the substrate using screws and screw anchors, calculating the fixing points at 30cm intervals on both sides. 3. Make the screed over the punched flanges of the structural or expansion joint, calculating the thickness of the final floor, and then lay the floor as normal.

ANGLES BAR / WALL

NATURAL ALUMINIUM

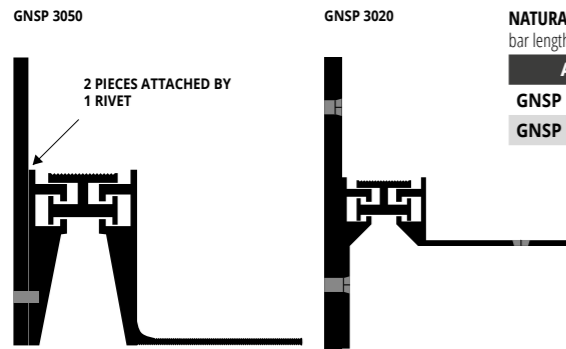

NATURAL ALUMINIUM ANGLES BAR
bar length 3 lm - pack. 10 Pcs - 30 lm

Article	L x H mm	€/lm	€/Pc
GNSP 3020	30 x 20	62,41	187,23 *
GNSP 3050	30 x 50	74,05	222,15 *

COLOURS



GNS 75... 18/50/80

NATURAL ALUMINIUM

Structural joint **GNS 75** is in good quality natural aluminium with neoprene in the lower central part and another aluminium profile in the upper visible part. It withstands heavy loads and frequent pedestrian traffic. Bar length 3 m, visible head width 75 mm. It withstands forklift trucks with rubber tyre and transpallets to a maximum total load of 6,5 kgs/mm².

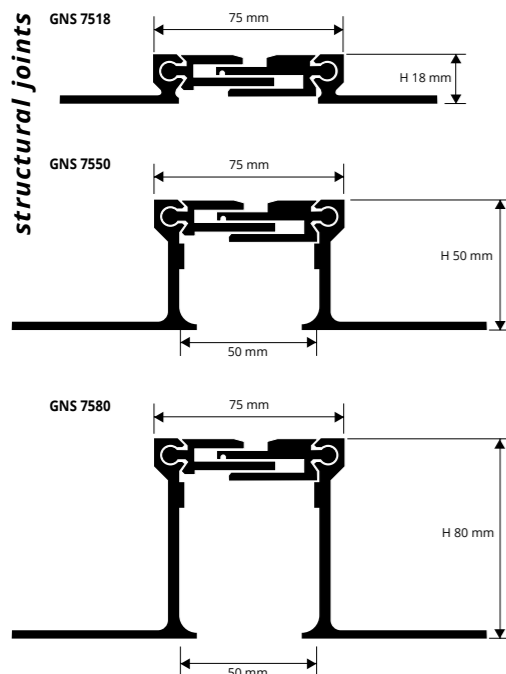

NATURAL ALUMINIUM
bar length 3 lm

Article	H mm	€/lm	€/Pc
GNS 7518	18	111,60	334,80 *
GNS 7550	50	133,28	399,84 *
GNS 7580	80	148,09	444,27 *

Movement mm: +10/-5 Horiz. +/- 5 Vert.

EXAMPLES AND INSTRUCTIONS FOR LAYING METHODS

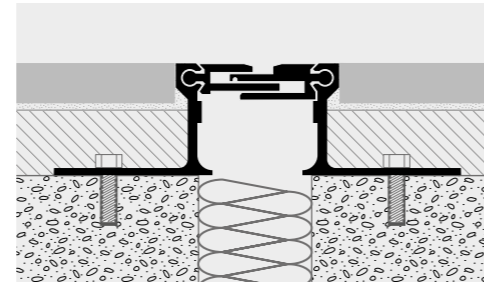

1. Choose the expansion joint with suitable height for the thickness of the floor and the screed/floor rough and choose the colour of the insert. 2. Fix the punched flanges to the substrate using screws and screw anchors, calculating the fixing points at 30cm intervals on both sides. 3. Make the screed over the punched flanges of the structural or expansion joint, calculating the thickness of the final floor, and then lay the floor as normal.

COLOURS



PROPLATE FIX is a range of flat joint-cover profiles to cover structural movements (contraction due to flexural or compressive stress) of two different load-bearing structures.

PROPLATE FIX made in silver anodized aluminium is recommended for environments with intense pedestrian and vehicular traffic. Available upon request with stainless steel fixing clips (5 Pcs. for vertical/façade use 10 Pcs. for horizontal/floor use); corner profiles are also available.

PROPLATE FIX

FLAT AND ANGLE PROFILE
IN ALUMINIUM



FLAT PROFILE - SILVER ANOD. ALUMINIUM
bar length 3 lm - pack. 20 Pcs - 60 lm

Article	L mm	€/lm	€/Pc
PETFXPAA 50	50	14,39	43,17
PETFXPAA 70	70	24,97	74,91



ANGLE PROFILE - SILVER ANOD. ALUMINIUM
bar length 3 lm - pack. 20 Pcs - 60 lm

Article	H x L mm	€/lm	€/Pc
PETFXAA 50	22 x 50	15,04	45,12 *
PETFXAA 70	24 x 70	22,37	67,11

PRODUCT SUPPLIED NOT ASSEMBLED

FIXING CLIPS BETWEEN 20 AND 45 mm - STAINLESS STEEL - pack. 10 Pcs

Article	H mm	€/Pc	€/Pack.
CPFXAC 40	40	1,91	19,10

COLOURS



EXAMPLES AND INSTRUCTIONS FOR LAYING METHODS

1. Choose the profile in the required width and material. 2. Insert the fixing clips into the relative groove, one every 50/75 cm (5 Pcs. for wall applications - 10 Pcs. for floor applications). 3. Insert/Lay the PROPLATE FIX in the existing void, applying uniform pressure or using a plastic hammer, thereby creating a perfect joint cover. The same method is used for laying the corner profile.

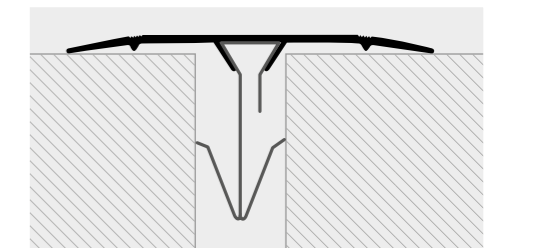
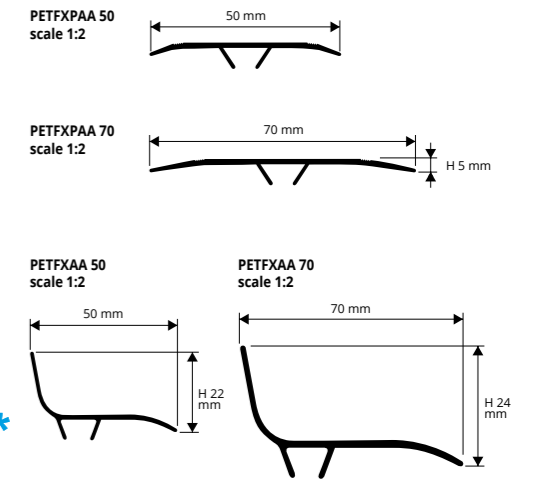

PROPLATE FIX is a range of flat joint-cover profiles to cover structural movements (contraction due to flexural or compressive stress) of two different load-bearing structures.

PROPLATE FIX made in rigid PVC is recommended for walls and facades and for ceilings. Available upon request with stainless steel fixing clips (5 Pcs. for vertical/façade use 10 Pcs. for horizontal/floor use); corner profiles are also available.

PROPLATE FIX

FLAT AND ANGLE PROFILE
IN VINYL RESIN (PVC)



FLAT PROFILE - VINYL RESIN (PVC)
bar length 3 lm - pack. 20 Pcs - 60 lm

Article	L mm	€/lm	€/Pc
PETFXP 50-01	50	9,57	28,71



ANGLE PROFILE - VINYL RESIN (PVC)
bar length 3 lm - pack. 20 Pcs - 60 lm

Article	H x L mm	€/lm	€/Pc
PETFX 50-01	22 x 50	9,89	29,67

PRODUCT SUPPLIED NOT ASSEMBLED

FIXING CLIPS BETWEEN 20 TO 45 mm - STAINLESS STEEL - pack. 10 Pcs

Article	H mm	€/Pc	€/Pack.
CPFXAC 40	40	1,91	19,10

COLOURS

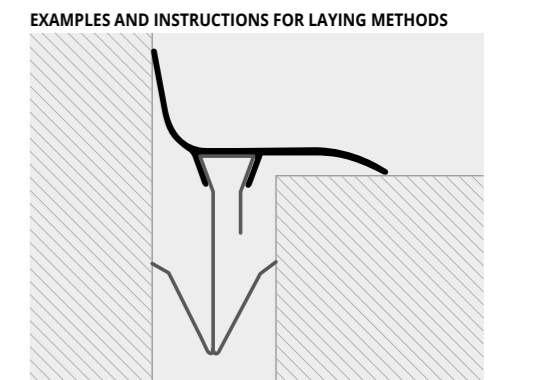
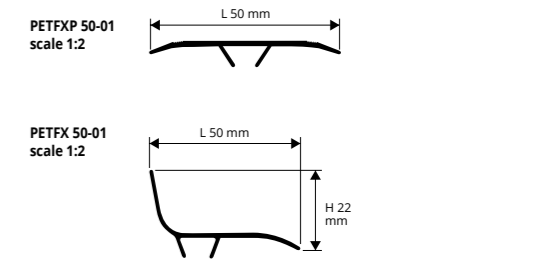
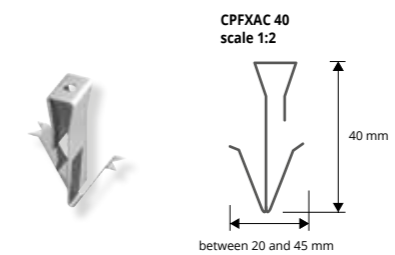
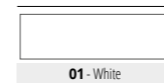

1. Choose the profile in the required width and material. 2. Insert the fixing clips into the relative groove (5 Pcs. for wall applications - 10 Pcs. for floor applications). 3. Insert/Lay the PROPLATE FIX in the existing void, applying uniform pressure or using a plastic hammer, thereby creating a perfect joint cover. The same method is used for laying the corner profile.